



Technical Paper

Software Defined Radio: A Promising Technology for Multi-Standard Base Stations

Wireless communication standards are evolving rapidly. Operators and system suppliers have inhomogeneous philosophies when it comes to providing a multitude of mobile communication standards, such as UMTS FDD, HSDPA, HSUPA and WiMAX. To enable the operators to reuse their existing infrastructures and sites, Alcatel is proposing to support the various air-interface standards using a single base-station architecture. This evolution, which is based on Alcatel's Node B product enhanced with a software defined radio approach, will expand operations by making very flexible use of multiple frequency bands and multiple standards using common hardware. Alcatel is currently investigating various multi-standard / multi-band approaches and architectures. A first laboratory prototype of a multi-band transceiver is already available and has demonstrated the technical feasibility of this approach.

B. Haberland, W. Koenig, A. Pascht, U. Weiss

SOFTWARE DEFINED RADIO: A PROMISING TECHNOLOGY FOR MULTI-STANDARD BASE STATIONS

SDR is an important step towards offering every user – at any location – the best service, bandwidth and mobility, in line with Alcatel’s vision of a user-centric broadband world.

Wireless systems are becoming more and more heterogeneous in terms of standards and the frequency bands they use. In the case of the Base Station Subsystem (BSS) and Radio Network Subsystem (RNS), the reusability of existing sites is particularly important when it comes to introducing a new radio standard because it has significant benefits for operators in terms of savings in both capital expenditure and operating expenses.

Multi-standard multi-band solutions are essential to enable equipment suppliers to reduce the number of development cycles, thereby cutting R&D costs and shortening the time-to-market. Fewer variants mean much lower maintenance, manufacturing and module improvement (cost reduction) efforts. However, all these advantages have to compensate for the possibly slightly higher cost of Software Defined Radio (SDR) solutions compared with dedicated solutions.

In “beyond 3G” systems, new air interfaces (e.g. WiMAX for hot spots and hot zones) and an extension of the multi-standard radio resource management procedures, are making SDR solutions ever more relevant for base station platforms.

For the operator, SDR offers greater flexibility in the deployment of different

standards and multiple frequency bands. For example, it can be used to rapidly introduce hot spots / hot zones reusing existing sites.

■ Technical Motivation

Alcatel’s SDR technologies are focusing on multi-band, multi-standard solutions. There is a differentiation between:

- Multi-band, single standard:
 - 1.8/2.1/2.6 GHz: Universal Mobile Telecommunications System (UMTS) R99.
 - 2.5/3.5 GHz: WiMAX according to the IEEE 802.16e standard.
- Multi-standard within one frequency band:
 - 2.1 GHz: UMTS R99, High Speed Downlink Packet Access (HSDPA), HSDPA enhancements, High Speed Uplink Packet Access (HSUPA) and the introduction of Orthogonal Frequency Division Multiplex (OFDM) in Third Generation (3G) systems.
- Multi-band, multi-standard:
 - 1.8/2.1/2.6 GHz: UMTS R99, HSDPA evolution, 3G OFDM.
 - 1.8/2.1/2.6 GHz / 3.5 GHz: UMTS R99, HSDPA evolution, 3G OFDM, WiMAX.

In addition, there is a work item in the Third Generation Partnership Project (3GPP) for UMTS900 that will pose additional challenges for SDR technology.

■ Basic Principles of Multi-Band/ Multi-Standard Transceivers

A multi-band transceiver (TRX) is a radio front-end that can be operated in a number of frequency bands. This is interesting in conjunction with UMTS Frequency Division Duplexing (FDD), where

Implemented multi-band front-end demonstrator in operation with signal source, analyzer and control environment



the standard already defines a set of operating bands. An Alcatel research project has successfully developed a first demonstration model of a Multi-Band Front-End (MBFE) operating in selected frequency bands (see Table 1).

The frequency bands can easily be changed without modifying the hardware, giving network operators considerable flexibility not only when introducing new frequency bands, but also for subsequent network reconfiguration and optimization.

Table 1: Selected frequency bands for MBFE implementation

Operating Band	Receive Frequency	Transmit Frequency
I	1920 – 1980 MHz	2110 – 2170 MHz
III	1710 – 1785 MHz	1805 – 1880 MHz
IV	1710 – 1755 MHz	2110 – 2155 MHz
Extension Band	2500 – 2570 MHz	2620 – 2690 MHz

Figure 1: Overall architecture of the MBFE

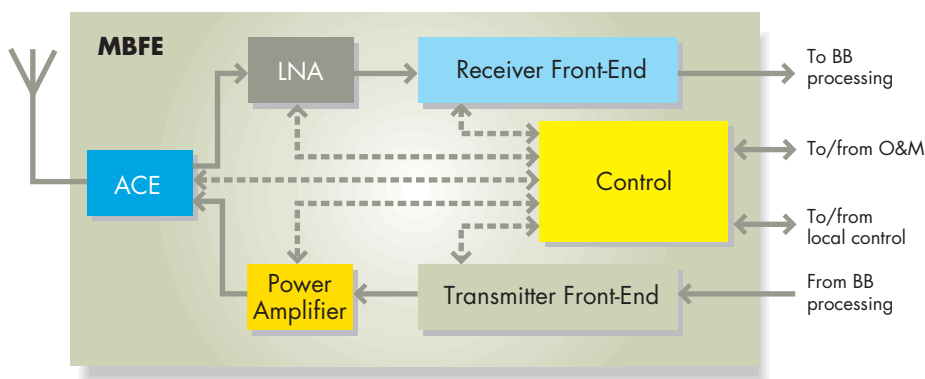

BB: BaseBand O&M: Operations and Maintenance

Figure 2: Implementation of (a) transmitter front-end, and (b) receiver front-end

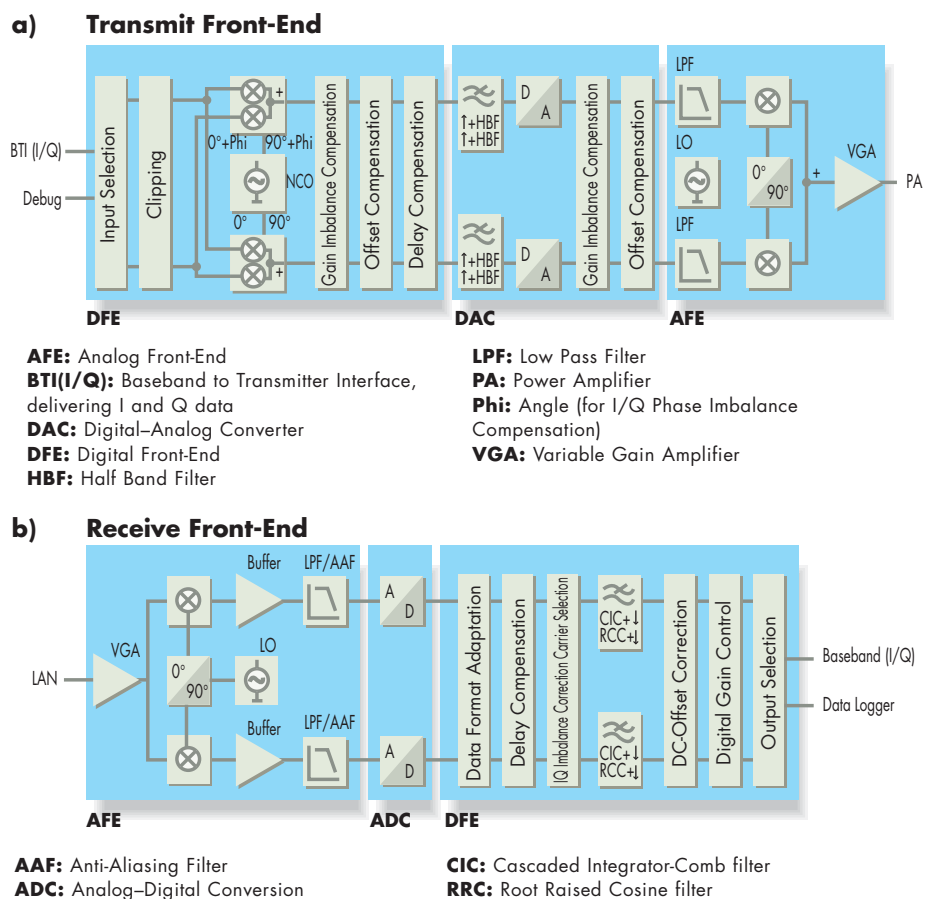

AFE: Analog Front-End
BTI(I/Q): Baseband to Transmitter Interface, delivering I and Q data
DAC: Digital-Analog Converter
DFE: Digital Front-End
HBF: Half Band Filter
LPF: Low Pass Filter
PA: Power Amplifier
Phi: Angle (for I/Q Phase Imbalance Compensation)
VGA: Variable Gain Amplifier

Architecture of a multi-band transceiver

Figure 1 depicts the modules deployed [1] in the MBFE, each of which must meet much more stringent requirements than those for a single-band approach.

The power amplifier (for the selected bands) has to operate over a wide frequency range from 1800 to 2700 MHz. The Antenna Coupling Equipment (ACE) selects the required bands (to and from the antenna) and separates the corre-

sponding transmit (TX) and receive (RX) sections (duplexer). The Low Noise Amplifier (LNA) performs the initial amplification of the received signals. The entire operation of the MBFE is managed by the control module.

The transmit and receive front-ends are both implemented using a direct conversion architecture (see Figure 2). The transmit front-end can be (re-)configured for two different modes of operation: zero Intermediate Frequency (IF)

mode or low IF mode, depending on the frequency of the Numerical Control Oscillator (NCO) in the digital front-end.

When the NCO is set to 0 (zero IF mode), the carrier is located around frequency zero in the baseband (Figure 3a, left side) and therefore only a single carrier can be treated in this case. After conversion (mixing) to Radio Frequency (RF) (Figure 3a, right side), in the RF band the carrier then appears symmetrically to the Local Oscillator (LO) frequency set in the analog front-end section (see Figure 3a).

In preparation for multi-carrier usage, the carrier can also be separated from the center frequency at a low IF, determined by the NCO frequency (see Figure 3b, left side). In this case, the carrier in the RF band (see Figure 3b, right side) appears to the left or right of the LO frequency. Emissions caused by imperfections in the analog In-phase and Quadrature (IQ) modulator (image and LO leakage) have to be eliminated (i.e. compensated).

The extension of the MBFE to a multi-standard base station covering UMTS FDD / HSDPA and WiMAX introduces new requirements. The multi-standard, multi-band transmitter/receiver needs to handle additional frequency bands and an enlarged bandwidth of 20 MHz, as well as to meet more stringent performance requirements resulting from the need for WiMAX to support OFDM signals.

Enabling components

Many of the components used to build an MBFE are operated at the edge of what is feasible today. In some areas this will entail significant improvements and developments by the component manufacturers:

- **Mixers:** Highly linear IQ (de)modulators working over a wide frequency range are needed to implement the direct-conversion architecture. The first products are just appearing on the market. As part of a nationally funded research project, Alcatel and its partners Lucent and Infineon, have specified and manufactured early samples that meet the requirements.
- **Synthesizer:** Wideband synthesizers covering the required frequency range are not yet available. Special samples have been developed for the demonstrator.
- **Converters:** Commercial digital-analog and analog-digital converters capable of handling arbitrary carriers inside one band are available.
- **Power amplifier:** Wideband applications are impossible using conventional

high power devices. However, new technologies (e.g. GaN) are emerging, but so far the achievable power is limited.

- **Multi-band duplexers:** Only dual-band duplexers are currently available. Today, the multi-band duplexer is a limiting factor because of its size and price. However, new technologies, like ceramic multi-mode filters, will help to reduce the size considerably.

■ ■ **Pre-compensation of “dirty RF”**

Wherever analog components are used, it is essential to take account of their imperfections that affect the overall behavior. Many of these imperfections can be compensated using digital pre-processing.

■ ■ ■ **Image suppression and LO leakage suppression in the transmitter**

When operating in low IF mode to meet the spectrum emission mask requirements, the image and LO leakage have to be carefully suppressed.

The image is a result of gain and phase imbalances in the I and Q (in phase and quadrature) branches of the analog IQ modulator, and can therefore be compensated by setting the corresponding gain and phase values appropriately in the digital part of these branches. LO leakage results from unpredicted DC offsets in the I and Q paths. In this case, compensation can be achieved by adding the inverse of the DC offset in the digital domain of each path.

The values for the compensation parameters are determined by analyzing the analog output signal with the help of a feedback loop.

Figure 3: Spectrum of direct upconversion (a) from zero IF, and (b) from low IF

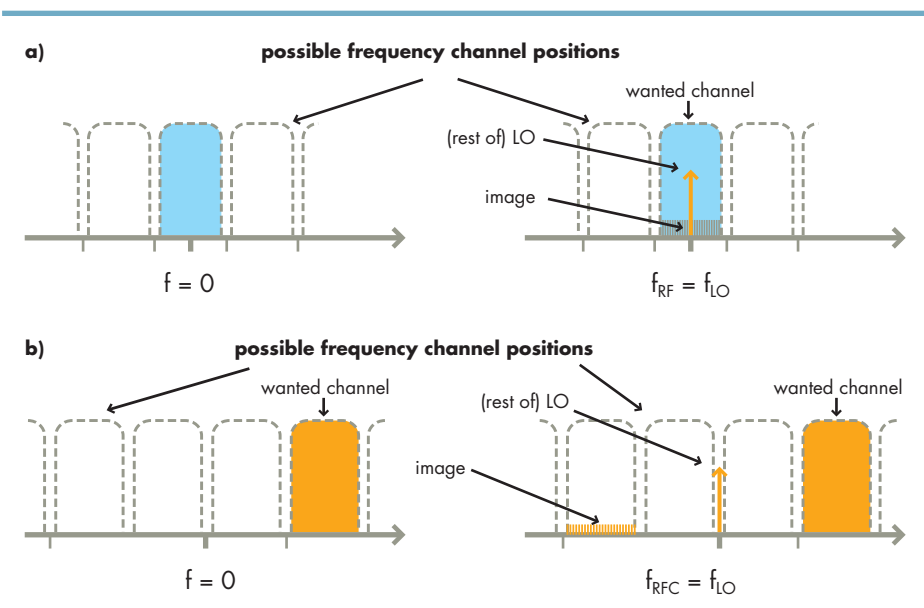

■ ■ ■ **Peak-to-average reduction**

This enables the power amplifier to be operated in a more efficient region. Because of the Quaternary Phase Shift Keying (QPSK) or Quadrature Amplitude Modulation (QAM) scheme used in Wideband Code Division Multiple Access (W-CDMA) and OFDM systems, the generated multi-carrier signal can feature a high peak-to-average power ratio of more than 10 dB. Without additional measures, the power amplifier would have to be operated with a high back-off from its 1 dB compression point in order to avoid large inter-modulation products. The peak-to-average reduction shown in Figure 4 enables the peaks to be reduced, leading to a peak-to-average ratio of around 5 dB.

The peak-to-average reduction must not generate spectral components outside the channel and the error vector magnitude of the resulting signal must stay within the 3GPP specification.

■ ■ ■ **Power amplifier linearization**

The signal data is pre-distorted with a nonlinear transfer characteristic inverse to the nonlinear transfer characteristic of the power amplifier. Consequently, the power amplifier can

be driven to the nonlinear part of its transfer characteristic, leading to an additional improvement in efficiency. To adjust the pre-distortion parameters adaptively, the output signal of the power amplifier has to be compared with the input signal of the pre-distortion [2]. Figure 5 shows the spectra of a one- and a four-carrier signal with and without digital pre-distortion.

■ ■ ■ **Lab test results**

In the receive chain, with regard to IQ demodulation and analog/digital conversion, it has been proven that the reference sensitivity level can be achieved over all the bands [1].

The current MBFE lab demonstrator comprises up-conversion, including all the reconfiguration and compensation mechanisms plus the wideband power amplifier driver stages. In zero IF mode operation, the specifications can be met across all bands.

In low IF mode operation, the compensation mechanisms for image and LO suppression are working well to meet all the requirements, including the spectrum emission mask, which is the most challenging in this case (see Figure 6).

■ **Architecture of a Multi-Standard Baseband Platform**

A multi-standard base station consists of a universal hardware platform that can be configured for a specific air interface by downloading the appropriate functional software. This should be possible during operation without any downtime of the base station. The functionality of the downloaded software components ranges from protocol stacks to physical layer processing algorithms.

Figure 4: Peak power reduction

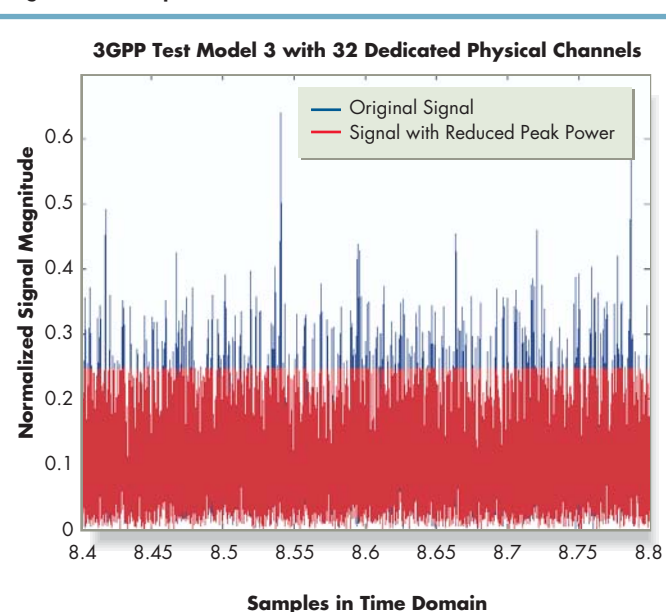

A multi-standard baseband platform must fit with the requirements of the applications to be supported (radio standards, operating modes) and has to dynamically support varying traffic mixes. Compared with conventional solutions, clear advantages can be obtained in terms of more efficient use of the existing hardware resources and the attainable Quality of Service (QoS).

High granularity is needed for the resources allocated to downlink and uplink signal processing. This requires architectural enhancements and intelligent and dynamic hardware resource management. A number of Digital Signal Processors (DSP) and hardware accelerator blocks are used for high bitrate and high volume data processing, as required for bit stream oriented functions. These elements are interconnected via a high speed data and control bus, and supervised by a control system (general purpose processor) (see Figure 7).

SDR baseband software library

A software library provides the signal processing building blocks needed to generate standard specific processing chains

High granularity

Refers to the degree of flexibility regarding the allocation of software tasks to processing elements like DSPs and FPGAs. In the context of re-configuration and load-sharing between different air interface standards it defines how finely the available processing performance can be split and assigned to different air interface functions.

Figure 5: Spectra of (top) a one-carrier and (bottom) a four-carrier signal (red) without and (blue) with pre-distortion.

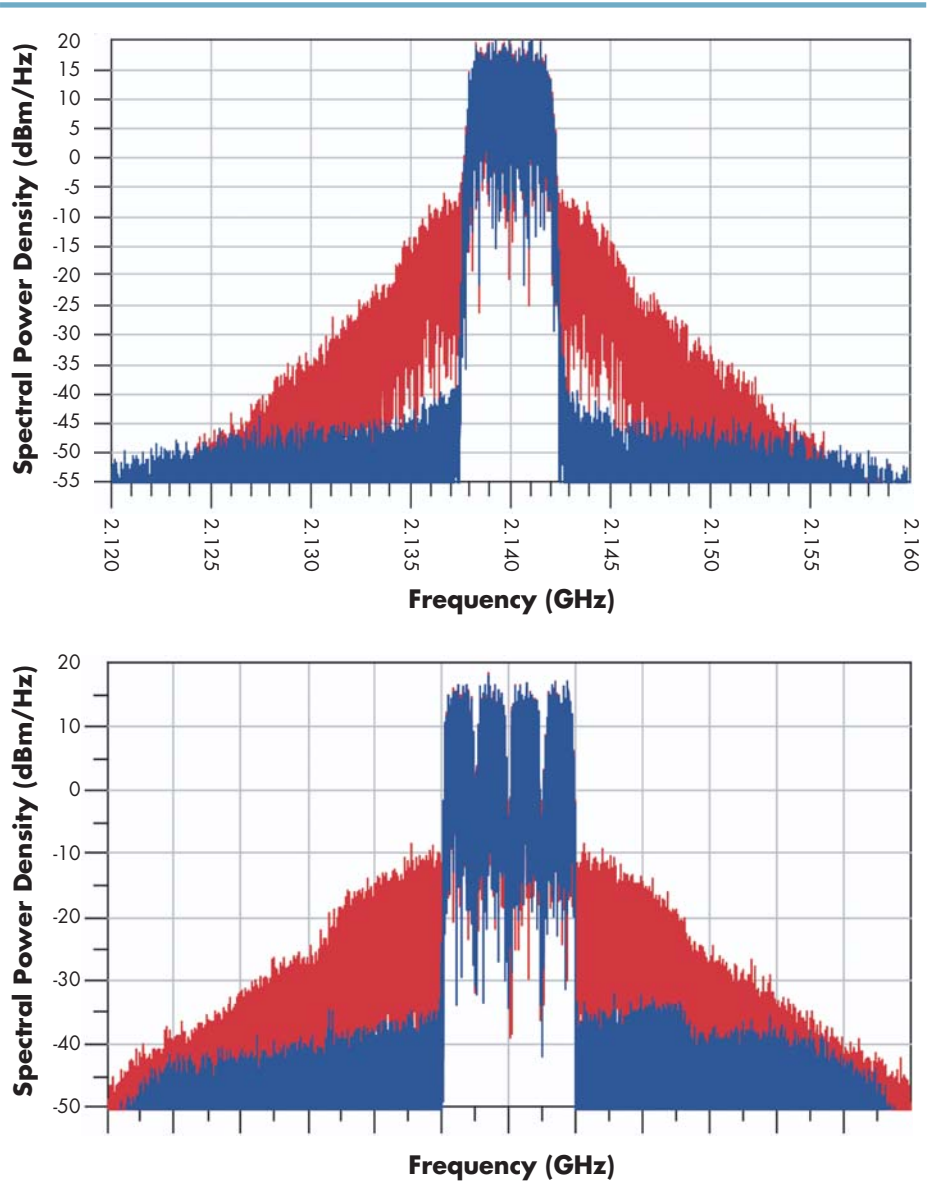
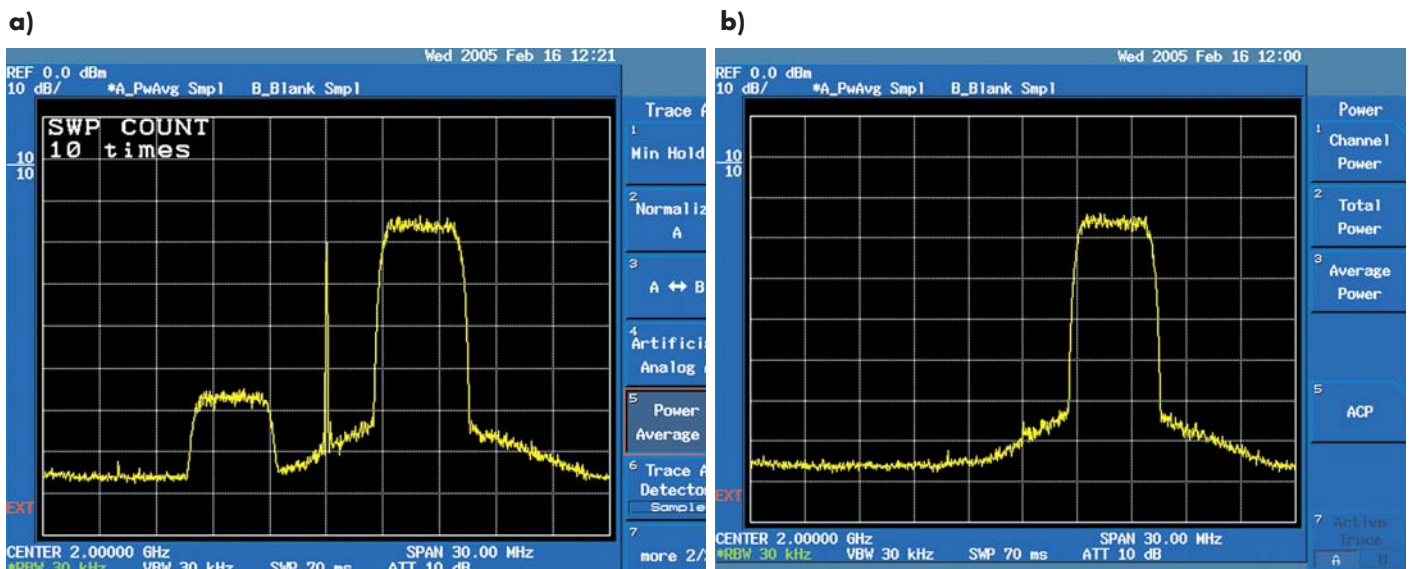

Figure 6: Direct conversion operated in low IF mode (a) without compensation and (b) with compensation



for downloading the downlink and uplink radio functionality to the processing elements, as required by the actual configuration. A suitable real-time operating system on the DSP level provides low layer functions to operate the hardware elements, for example, task management and scheduling. Resource and load management functions are realized using a hierarchical approach from the control system.

Before the runtime software is downloaded to the processing elements it is parameterized and linked together according to the required functionality. A scheduler in the DSP then calls the processing blocks in the appropriate way.

The processing chains (UMTS or WiMAX entity, etc) can be composed and configured from the dedicated part, the common part and the common algo-

rithm part of the system library, depending on the required air interface protocol (Figure 8).

Dedicated system libraries provide the unique functions for a specific air interface environment, defined by the given standard (e.g. transport block concatenation, interleaving, radio frame segmentation).

Common system libraries consist of system functions that are common to different air interfaces, which may need to be configured by setting suitable parameters to

Figure 7: Baseband hardware architecture

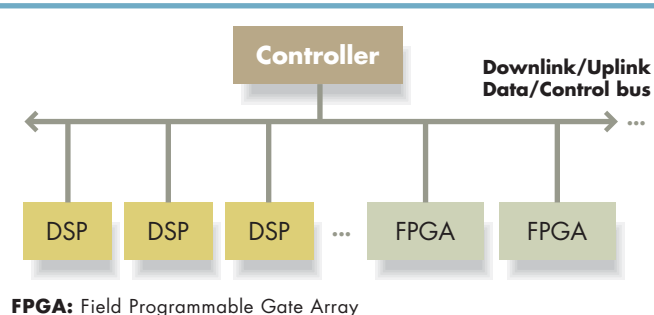

FPGA: Field Programmable Gate Array

match the functionality of a particular standard. Functions to be considered here include, for example, cyclic redundancy checking, spreading, modulation and power control.

Fast Fourier Transform (FFT)

Computationally efficient algorithm for performing a complete discrete Fourier transform, i.e. a transform of a signal from the time domain into the frequency domain.

Common algorithm libraries generally consist of basic functions that are widely used in the scientific and telecom fields, such as filtering functions, complex/real Fast Fourier Transform (FFT) functions and vector maths functions.

The application of a hierarchical SDR library concept has the potential to provide cost-effective solutions not only for software development, but also with respect to the memory required to store the huge volume of software codes. However, further studies and evaluations are necessary to prove the practicality of this approach [3].

Figure 8: Hierarchical SDR library concept for baseband signal processing

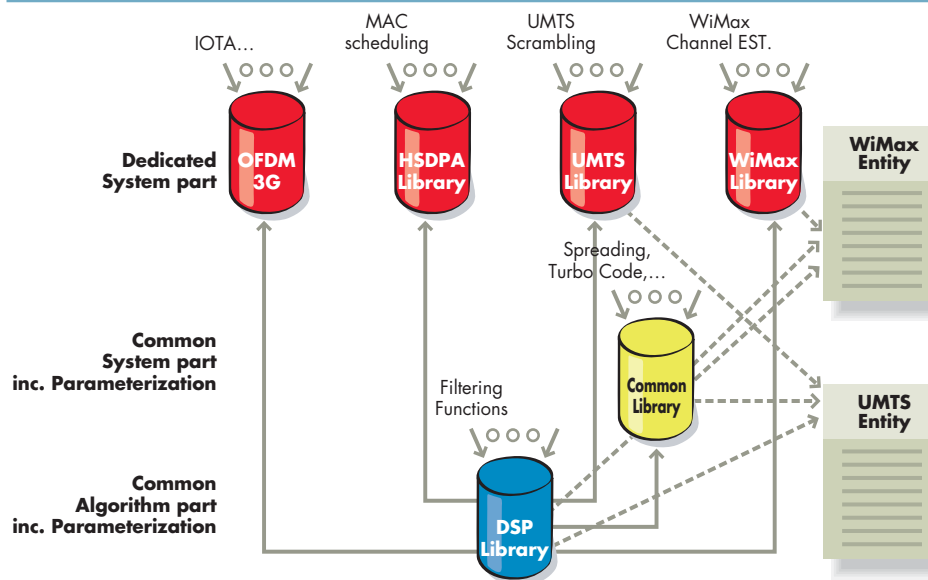
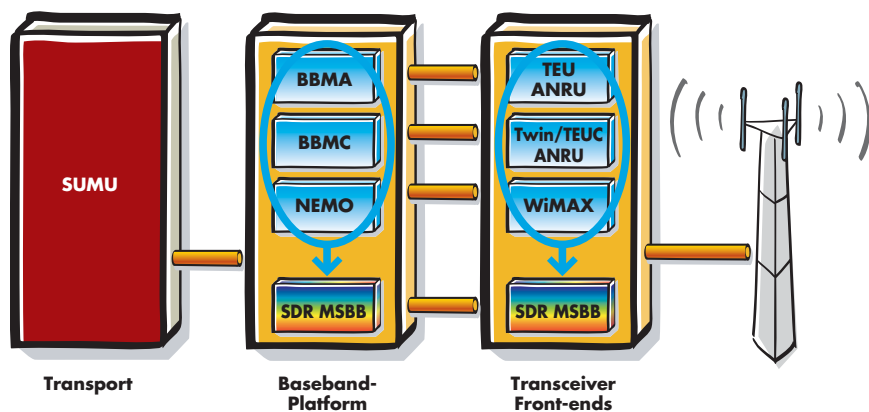

Figure 9: SDR will merge today's separate implementations into a single future-proof module



ANRU: Antenna Network and Receiver UMTS
BBMA: BaseBand Module revision A
BBMC: BaseBand Module revision C

NEMO: Network and Modem
MSBB: Multi-Standard BaseBand
TEU: Transmitter Equipment UMTS

Impact of SDR Technologies on the Node B Product Portfolio

Alcatel base station

Today dedicated solutions are available for different standards (see Figure 9). SDR technologies will enable the processing units to become more flexible in their treatment of different standards and frequency bands, thereby minimizing the number of hardware variants. In addition, it allows dynamic reconfiguration and parallel operation of different standards on the same platform at the same time. Thus it improves utilization of the processing power and therefore the overall system performance.

It is clear that multi-standard O&M and transport termination solutions are needed for the Station Unit Module Universal (SUMU). These are realized by software. The introduction of IP transport makes it easier to share the Iub transport

resources than was the case with the Asynchronous Transfer Mode (ATM).

Baseband processing is done primarily with programmable software devices, such as DSPs and hardware accelerators (e.g. field programmable gate arrays). This is an opportunity to introduce multi-standard solutions.

Shifting most of the complexity of the transceiver architecture (e.g. TEU; ANRU) to the digital part, enables operation in different bands and to different standards. This also has a positive effect on costs, because the price of digital processing components is approximately halving every year, whereas the prices for analog RF components are declining at no more than 10% per year.

Evolutionary phases

Different evolutionary phases with increasing complexity and flexibility for the operator can be identified for both the baseband part and the transceiver part. The individual steps are described below.

Evolutionary phases for the baseband part

An example based on a system with a pool of 11 baseband boards demonstrates the different levels of reconfiguration:

- Reconfigurable software solutions that enable the hardware platform (i.e. all equipped baseband boards together) to be used for either standard A or standard B.



- Parallel operation of standards A and B, but only one dedicated standard per baseband board. Load sharing based on software reconfiguration is foreseen at the level of the baseband platform.



- Parallel operation of standards A and B with dynamic load sharing at the baseband board level on a call-by-call basis.



Multi-band/multi-standard transceiver

- Single standard transmitter/receiver with multi-band operation. The following applications are of added value:
 - 1.7 GHz to 2.7 GHz for 3G+ (UMTS 1800, UMTS core band, UMTS 2600);
 - 2.5 GHz to 3.5 GHz for WiMAX.
- Software reconfigurable multi-band/multi-standard transmitter/receiver (only standard A or B in operation). The following applications can be identified:
 - 1.7 GHz to 2.7 GHz for 3G+ and WiMAX (2500);
 - 2.5 GHz to 3.5 GHz for 3G+ (UMTS 2600) and WiMAX (3500).
- Multi-band/multi-standard transmitter/receiver in parallel operation (standards A and B operate in parallel). The same combinations as in the previous case are of interest.

Conclusion

Software defined radio is an enabling technology for multi-standard/multi-band base stations. A multi-band front-end lab demonstrator has already been built and is operating not only in the UMTS core band but also in the GSM1800 band and the 2.6 GHz extension band. A direct conversion architecture has been used with image suppression and LO leakage suppression. Additional features, including peak-to-average reduction and digital pre-distortion for power amplifier linearization, are also ready to be used. Regarding the multi-standard capabilities of the baseband platform, the hierarchical SDR library concept is a powerful approach to the implementation of cost-effective solutions.

Multi-standard/multi-band solutions are relevant for flexible, software recon-

figurable base stations. They will enable Alcatel to extend its product portfolio. This is especially true for a multi-standard combination of 3G evolution and WiMAX.

SDR technology reduces the number of dedicated developments for different standards and frequency bands. This is important for Alcatel because both fewer product variants and fewer development cycles reduce R&D costs. In addition, SDR-based solutions are future-safe as features can be upgraded by software.

For customers, the SDR approach offers new opportunities for dynamic network reconfiguration (e.g. introduction of hot spots) and the reuse of existing sites and equipment, leading to significant reductions in capital expenditure and operating expenses. Furthermore, the high flexibility can serve as the basis for future infrastructure sharing.



Bernd Haberland is head of all radio activities in the Research & Innovation center, Stuttgart, Germany. He is also project leader of the Alcatel

"Radio Protocols and BTS Nodes" project with activities in Stuttgart and Shanghai, and a Fellow Member of the Alcatel Technical Academy.

(Bernd.Haberland@alcatel.de)



Wolfgang Koenig is Unit Manager for Advanced Transceiver Solutions within the Alcatel Research & Innovation center, Stuttgart, Germany.

(Wolfgang.Koenig@alcatel.de)



Andreas Pascht is Team Leader for Integrated Radio at the Research & Innovation center in Stuttgart, Germany. He is a Distinguished Member

of the Alcatel Technical Academy.
(Andreas.Pascht@alcatel.de)



Ulrich Weiss is working on research in the Multi-Band Transceiver Front-End at the Alcatel Research & Innovation center, Stuttgart, Germany.

(u.weiss@alcatel.de)

References

- W. Koenig, G. Luz, S. Walter, U. Weiss: "Implementation of a Multi-band Front-end for a Medium Range Base Station within the RMS Project: Test and Measurement Results", *SDR Forum Technical Conference*, 16-18 November 2004, Phoenix, Arizona, USA.
- T. Bitzer, F. Endress, A. Pascht, M. Schreiter: "Imbalance-Compensated Direct Down Conversion Receiver for UMTS Base Stations", *IEEE Microwave and Wireless Components Letters*, August 2004, volume 14, number 8, page 395-397.
- S. Walter, M. Bronzel, J. Brakensiek et al: "Functional Elements in E2E Reconfigurable Equipment", *IST Mobile Summit*, June 2004, Lyon, France.

■ Abbreviations

2G	2nd Generation of mobile communication standards	TEU	Transmitter Equipment UMTS
3G	3rd Generation of mobile communication systems	TEUC	Transmitter Equipment UMTS Revision C
3GPP	3rd Generation Partnership Project, standardization body for UMTS	TRX	Transmit and Receive / Transceiver
ACE	Antenna Coupling Equipment	TX	Transmit / Transmitter
ADC	Analogue to Digital Converter	UMTS	Universal Mobile Telecommunications System
AFE	Analogue Front-End	W-CDMA	Wideband CDMA
ANRU	Antenna Network and Receiver UMTS	WiMAX	Worldwide Interoperability for Microwave Access (IEEE 802.16e standard)
ATM	Asynchronous Transfer Mode		
BB	Base Band		
BBMA	Base Band Module Revision A		
BBMC	Base Band Module Revision C		
BSS	Base Station Subsystem		
BTS	Base Transceiver Station		
CAPEX	Capital Expenditure		
CDMA	Code Division Multiple Access		
CRC	Cyclic Redundancy Check		
DAC	Digital to Analogue Converter		
DFE	Digital Front-End		
DSP	Digital Signaling Processor/Processing		
FDD	Frequency Division Duplex		
FFT	Fast Fourier Transformation		
FPGA	Field Programmable Gate Array		
GPP	General Purpose Processor		
GSM	Global System for Mobile communication		
HSDPA	High Speed Downlink Packet Access		
HSUPA	High Speed Uplink Packet Access		
HW	Hardware		
IF	Intermediate Frequency		
IQ	In-phase and Quadrature		
LNA	Low Noise Amplifier		
LO	Local Oscillator		
MB	Multi-Band		
MBFE	Multi-Band Front-End covering the radio transmitter and receiver of a Base Station		
MS	Multi-Standard		
Mx	Multi-Standard		
MxMB	Multi-Standard/Multi-Band		
NCO	Numeric Controlled Oscillator		
NEMO	Network and Modem		
Node B	UMTS Base Station		
O&M	Operation and Maintenance		
OFDM	Orthogonal Frequency Division Multiplex		
OPEX	Operational Expenditure		
PA	Power Amplifier		
QAM	Quadrature Amplitude Modulation		
QoS	Quality of Service		
QPSK	Quaternary Phase Shift Keying		
RAT	Radio Access Technology		
RF	Radio Frequency		
RNS	Radio Network Subsystem		
RX	Receive / Receiver		
SDR	Software Defined Radio		
SUMU	Station Unit Module UMTS/Universal		
SW	Software		

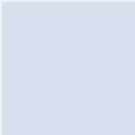
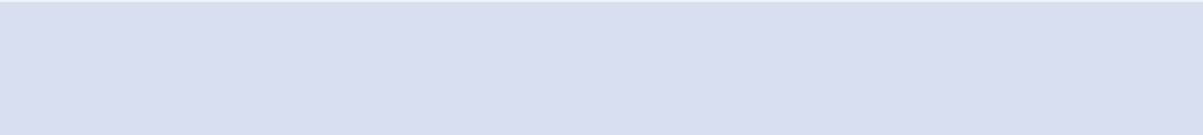

Alcatel and the Alcatel logo are registered trademarks of Alcatel. All other trademarks are the property of their respective owners. Alcatel assumes no responsibility for the accuracy of the information presented, which is subject to change without notice.
© 05 2005 Alcatel. All rights reserved. 3GQ 00011 0005 TQZZA Ed.01

